

- 1.5 Amp Source/Sink Drive
- Pin Compatible with 0026 Products
- 40 ns Rise and Fall into 1000pF
- Low Quiescent Current
- 5 V to 40 V Operation
- Thermal Protection

description

The UC3709 family of power drivers is an effective low-cost solution to the problem of providing fast turn-on and off for the capacitive gates of power MOSFETs. Made with a high-speed Schottky process, these devices will provide up to 1.5 A of either source or sink current from a totem-pole output stage configured for minimal cross-conduction current spike.

The UC3709 is pin compatible with the MMH0026 or DS0026, and while the delay times are longer, the supply current is much less than these older devices.

With inverting logic, these units feature complete TTL compatibility at the inputs with an output stage that can swing over 30 V. This design also includes thermal shutdown protection.

simplified schematic (only one driver shown)

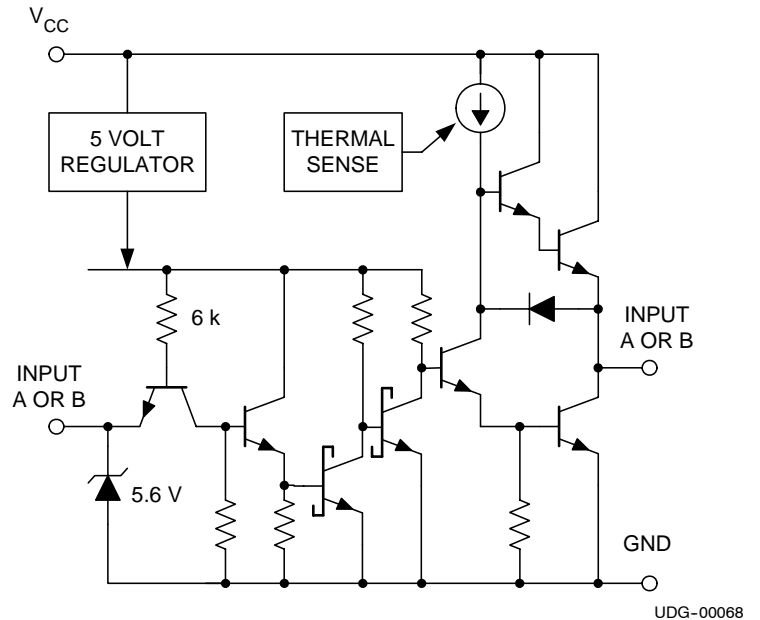

absolute maximum ratings over operating free-air temperature range (unless otherwise noted)^{†‡}

Parameter	DW PACKAGE	J PACKAGE	L PACKAGE	N PACKAGE	UNIT
Supply Voltage, V_{CC}	40	40	40	40	V
Output Current (Source or Sink)					
..... Steady-State	±500	±500	±500	±500	mA
..... Peak Transient	±1.5	±1.0	±1.0	±1.5	A
..... Capacitive Discharge Energy	20	15	15	20	mJ
Digital Inputs [‡]	5.5	5.5	5.5	5.5	V
Power Dissipation at $T_A = 25^\circ\text{C}$	1	1	1	1	W
Power Dissipation at $T_C = 25^\circ\text{C}$	3	2	2	3	W
Operating Junction Temperature Range (T_J)	-55 to 125	-55 to 125	-55 to 125	-55 to 125	$^\circ\text{C}$
Storage Temperature Range	-65 to 150	-65 to 150	-65 to 150	-65 to 150	$^\circ\text{C}$
Lead Temperature (Soldering, 10 Seconds)	300	300	300	300	$^\circ\text{C}$

[†] Stresses beyond those listed under "absolute maximum ratings" may cause permanent damage to the device. These are stress ratings only, and functional operation of the device at these or any other conditions beyond those indicated under "recommended operating conditions" is not implied. Exposure to absolute-maximum-rated conditions for extended periods may affect device reliability.

[‡] All currents are positive into and negative out of the specified terminals. Digital drive can exceed 5.5V if input is limited to 10mA. Consult the Packaging Section of the Databook for thermal limitations and considerations of the package.



Please be aware that an important notice concerning availability, standard warranty, and use in critical applications of Texas Instruments semiconductor products and disclaimers thereto appears at the end of this data sheet.

PRODUCTION DATA information is current as of publication date. Products conform to specifications per the terms of Texas Instruments standard warranty. Production processing does not necessarily include testing of all parameters.

UC1709, UC2709, UC3709 DUAL HIGH-SPEED FET DRIVER

SLUS196C - NOVEMBER 1996 - REVISED FEBRUARY 2008

THERMAL RESISTANCE TABLE

PACKAGE	$\theta_{jc} (^{\circ}\text{C}/\text{W})$	$\theta_{ja} (^{\circ}\text{C}/\text{W})$
SOIC-16 (DW)	20 ⁽¹⁾	35 to 58 ⁽³⁾
DIL-16 (J)	28 ⁽²⁾	125 to 160
LCC-16 (L)	20 ⁽²⁾	70 to 80
DIL-16 (N)	45	90 ⁽³⁾

- NOTES: (1) Specified thermal resistance is θ_{jl} (junction to lead) where noted.
 (2) θ_{jc} data values stated were derived from MIL-STD-1835B. MIL-STD-1835B states, "The baseline values shown are worst case (mean +2s) for a 60x60 mil microcircuit device silicon die and applicable for devices with die sizes up to 14400 square mils. For device die sizes greater than 14400 square mils use the following values; dual-in-line, 11°C/W; flat pack, .10°C/W; pin grid array, 10°C/W".
 (3) Specified θ_{ja} (junction to ambient) is for devices mounted to 5-inch² FR4 PC board with one ounce copper where noted. When resistance range is given, lower values are for 5 inch² aluminum PC board. Test PWB was 0.062 inch thick and typically used 0.635-mm trace widths for power packages and 1.3-mm trace widths for non-power packages with a 100-mil x 100-mil probe land area at the end of each trace.

**LCC-20 (TOP VIEW)
L PACKAGES**

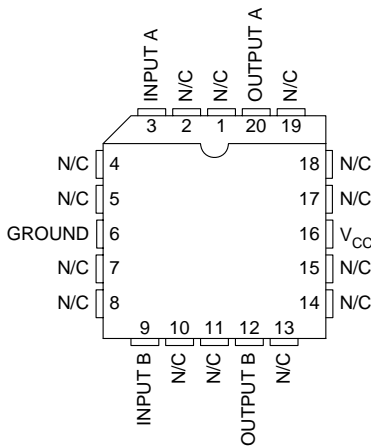

**8 PIN DIL N OR J PACKAGE
(TOP VIEW)**

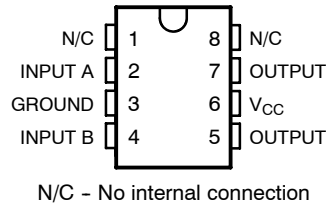

**SOIC-16 (TOP VIEW)
DW PACKAGE**

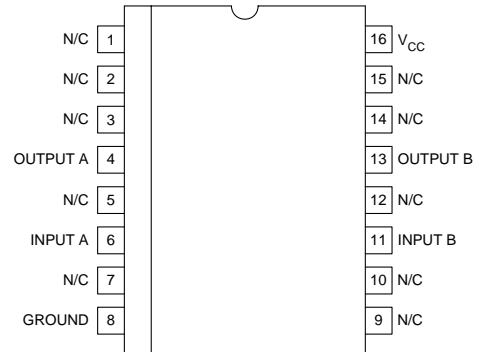

UC1709, UC2709, UC3709 DUAL HIGH-SPEED FET DRIVER

SLUS196C - NOVEMBER 1996 - REVISED FEBRUARY 2008

electrical characteristics over recommended operating free-air temperature range, $T_A = 55^\circ\text{C}$ to 125°C for the UC1709, -40°C to 85°C for the UC2709, and 0°C to 70°C for the UC3709; $V_{CC} = 20\text{ V}$, $T_A = T_J$.

PARAMETER	TEST CONDITIONS	MIN	TYP	MAX	UNIT
Supply current	Both outputs low		10	12	mA
	Both outputs high		7	10	mA
Logic 0 input voltage				0.8	V
Logic 1 input voltage		2.2			V
Input current	$V_I = 0$		-0.6	-1.0	mA
Input leakage	$V_I = 5\text{ V}$		0.05	0.1	mA
Output high saturation $V_{CC}-V_O$	$I_O = -50\text{ mA}$		1.5	2.0	V
	$I_O = -500\text{ mA}$		2.0	2.5	V
Output low saturation V_O	$I_O = 50\text{ mA}$		0.1	0.4	V
	$I_O = 500\text{ mA}$		2.0	2.5	V
Thermal shutdown			155		mA

typical switching characteristics, $V_{CC} = 20\text{ V}$, $T_A = 25^\circ\text{C}$, delays measured to 10% output change

PARAMETER	TEST CONDITIONS	OUTPUT $C_L =$		UNITS
		0 nF	2.2 nF	
Rise time delay		80	80	ns
10% to 90% rise		20	40	ns
Fall time delay		60	80	ns
10% to 90% fall		20	40	ns
VCC cross-conduction current spike duration	Output rise	25		ns
	Output fall	0		ns

NOTE: Refer to UC1705 specifications for further information.

APPLICATION INFORMATION

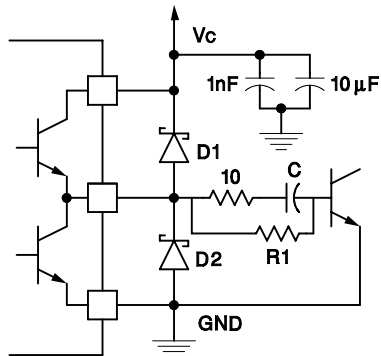

D1, D2: UC3611 Schottky Diodes

Figure 1. Power bipolar drive circuit.

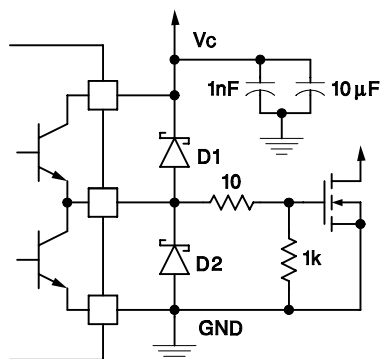

D1, D2: UC3611 Schottky Diodes

Figure 2. Power MOSFET drive circuit.

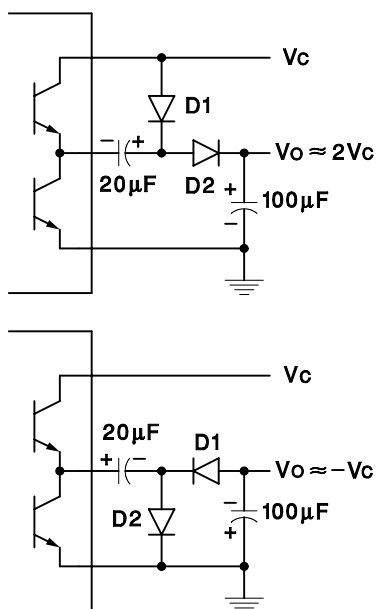

Figure 3. Charge pump circuits.

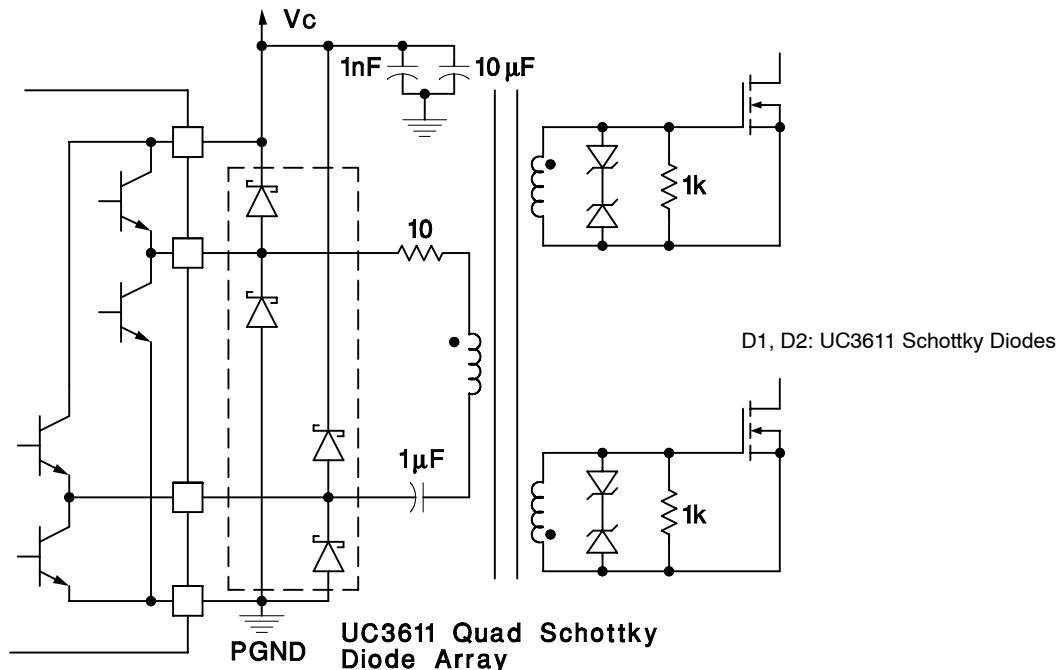

Figure 4. Transformer coupled push-pull MOSFET drive circuit.

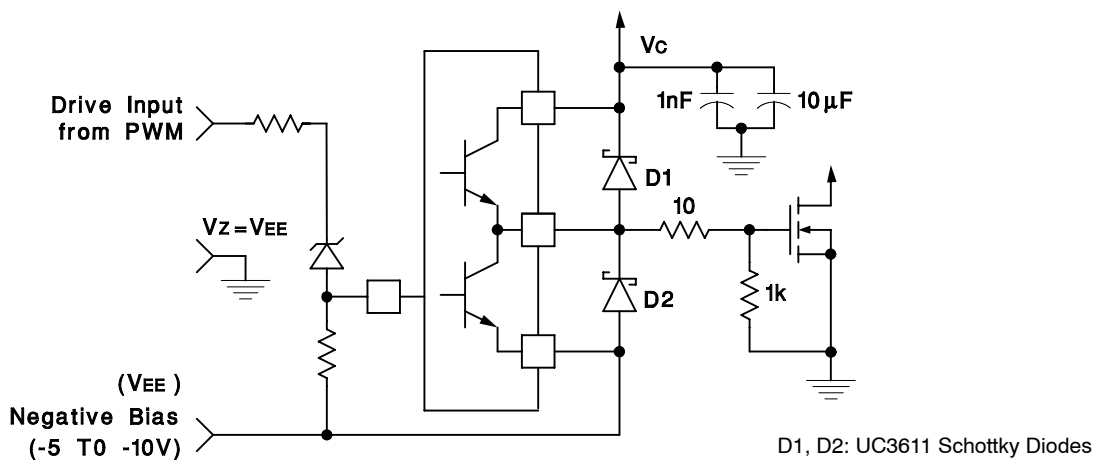
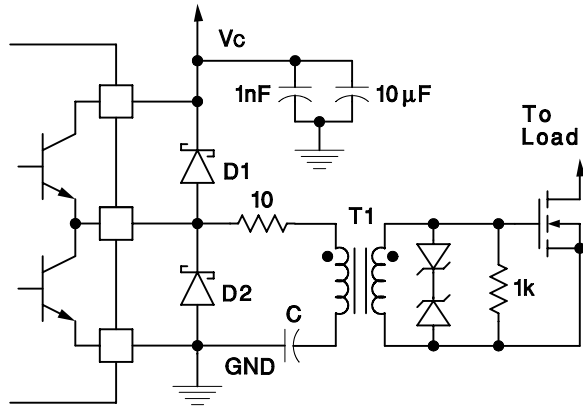

Figure 5. Power MOSFET drive circuit using negative bias voltage and level shifting to ground referenced PWM

UC1709, UC2709, UC3709 DUAL HIGH-SPEED FET DRIVER

SLUS196C - NOVEMBER 1996 - REVISED FEBRUARY 2008



D1, D2: UC3611 Schottky Diodes

Figure 6. Transformer coupled MOSFET drive circuit.

PACKAGING INFORMATION

Orderable Device	Status ⁽¹⁾	Package Type	Package Drawing	Pins	Package Qty	Eco Plan ⁽²⁾	Lead/Ball Finish	MSL Peak Temp ⁽³⁾
5962-0151201VPA	ACTIVE	CDIP	JG	8	1	TBD	A42	N / A for Pkg Type
UC1709J	ACTIVE	CDIP	JG	8	1	TBD	A42 SNPB	N / A for Pkg Type
UC1709J883B	ACTIVE	CDIP	JG	8	1	TBD	A42 SNPB	N / A for Pkg Type
UC1709L	ACTIVE	LCCC	FK	20	1	TBD	POST-PLATE	N / A for Pkg Type
UC1709L883B	ACTIVE	LCCC	FK	20	1	TBD	POST-PLATE	N / A for Pkg Type
UC2709DW	ACTIVE	SOIC	DW	16	40	Green (RoHS & no Sb/Br)	CU NIPDAU	Level-2-260C-1 YEAR
UC2709DWG4	ACTIVE	SOIC	DW	16	40	Green (RoHS & no Sb/Br)	CU NIPDAU	Level-2-260C-1 YEAR
UC2709N	ACTIVE	PDIP	P	8	50	Green (RoHS & no Sb/Br)	CU NIPDAU	N / A for Pkg Type
UC2709NG4	ACTIVE	PDIP	P	8	50	Green (RoHS & no Sb/Br)	CU NIPDAU	N / A for Pkg Type
UC3709DW	ACTIVE	SOIC	DW	16	40	Green (RoHS & no Sb/Br)	CU NIPDAU	Level-2-260C-1 YEAR
UC3709DWG4	ACTIVE	SOIC	DW	16	40	Green (RoHS & no Sb/Br)	CU NIPDAU	Level-2-260C-1 YEAR
UC3709N	ACTIVE	PDIP	P	8	50	Green (RoHS & no Sb/Br)	CU NIPDAU	N / A for Pkg Type
UC3709NG4	ACTIVE	PDIP	P	8	50	Green (RoHS & no Sb/Br)	CU NIPDAU	N / A for Pkg Type

⁽¹⁾ The marketing status values are defined as follows:

ACTIVE: Product device recommended for new designs.

LIFEBUY: TI has announced that the device will be discontinued, and a lifetime-buy period is in effect.

NRND: Not recommended for new designs. Device is in production to support existing customers, but TI does not recommend using this part in a new design.

PREVIEW: Device has been announced but is not in production. Samples may or may not be available.

OBSOLETE: TI has discontinued the production of the device.

⁽²⁾ Eco Plan - The planned eco-friendly classification: Pb-Free (RoHS), Pb-Free (RoHS Exempt), or Green (RoHS & no Sb/Br) - please check <http://www.ti.com/productcontent> for the latest availability information and additional product content details.

TBD: The Pb-Free/Green conversion plan has not been defined.

Pb-Free (RoHS): TI's terms "Lead-Free" or "Pb-Free" mean semiconductor products that are compatible with the current RoHS requirements for all 6 substances, including the requirement that lead not exceed 0.1% by weight in homogeneous materials. Where designed to be soldered at high temperatures, TI Pb-Free products are suitable for use in specified lead-free processes.

Pb-Free (RoHS Exempt): This component has a RoHS exemption for either 1) lead-based flip-chip solder bumps used between the die and package, or 2) lead-based die adhesive used between the die and leadframe. The component is otherwise considered Pb-Free (RoHS compatible) as defined above.

Green (RoHS & no Sb/Br): TI defines "Green" to mean Pb-Free (RoHS compatible), and free of Bromine (Br) and Antimony (Sb) based flame retardants (Br or Sb do not exceed 0.1% by weight in homogeneous material)

⁽³⁾ MSL, Peak Temp. -- The Moisture Sensitivity Level rating according to the JEDEC industry standard classifications, and peak solder temperature.

Important Information and Disclaimer:The information provided on this page represents TI's knowledge and belief as of the date that it is provided. TI bases its knowledge and belief on information provided by third parties, and makes no representation or warranty as to the accuracy of such information. Efforts are underway to better integrate information from third parties. TI has taken and continues to take reasonable steps to provide representative and accurate information but may not have conducted destructive testing or chemical analysis on incoming materials and chemicals. TI and TI suppliers consider certain information to be proprietary, and thus CAS numbers and other limited information may not be available for release.

In no event shall TI's liability arising out of such information exceed the total purchase price of the TI part(s) at issue in this document sold by TI

to Customer on an annual basis.

FK (S-CQCC-N**)

LEADLESS CERAMIC CHIP CARRIER

28 TERMINAL SHOWN



4040140/D 10/96

- NOTES:
- A. All linear dimensions are in inches (millimeters).
 - B. This drawing is subject to change without notice.
 - C. This package can be hermetically sealed with a metal lid.
 - D. The terminals are gold plated.
 - E. Falls within JEDEC MS-004

P (R-PDIP-T8)

PLASTIC DUAL-IN-LINE



- NOTES: A. All linear dimensions are in inches (millimeters).
 B. This drawing is subject to change without notice.
 C. Falls within JEDEC MS-001

For the latest package information, go to http://www.ti.com/sc/docs/package/pkg_info.htm

JG (R-GDIP-T8)

CERAMIC DUAL-IN-LINE



- NOTES: A. All linear dimensions are in inches (millimeters).
 B. This drawing is subject to change without notice.
 C. This package can be hermetically sealed with a ceramic lid using glass frit.
 D. Index point is provided on cap for terminal identification.
 E. Falls within MIL STD 1835 GDIP1-T8

DW (R-PDSO-G16)

PLASTIC SMALL-OUTLINE PACKAGE

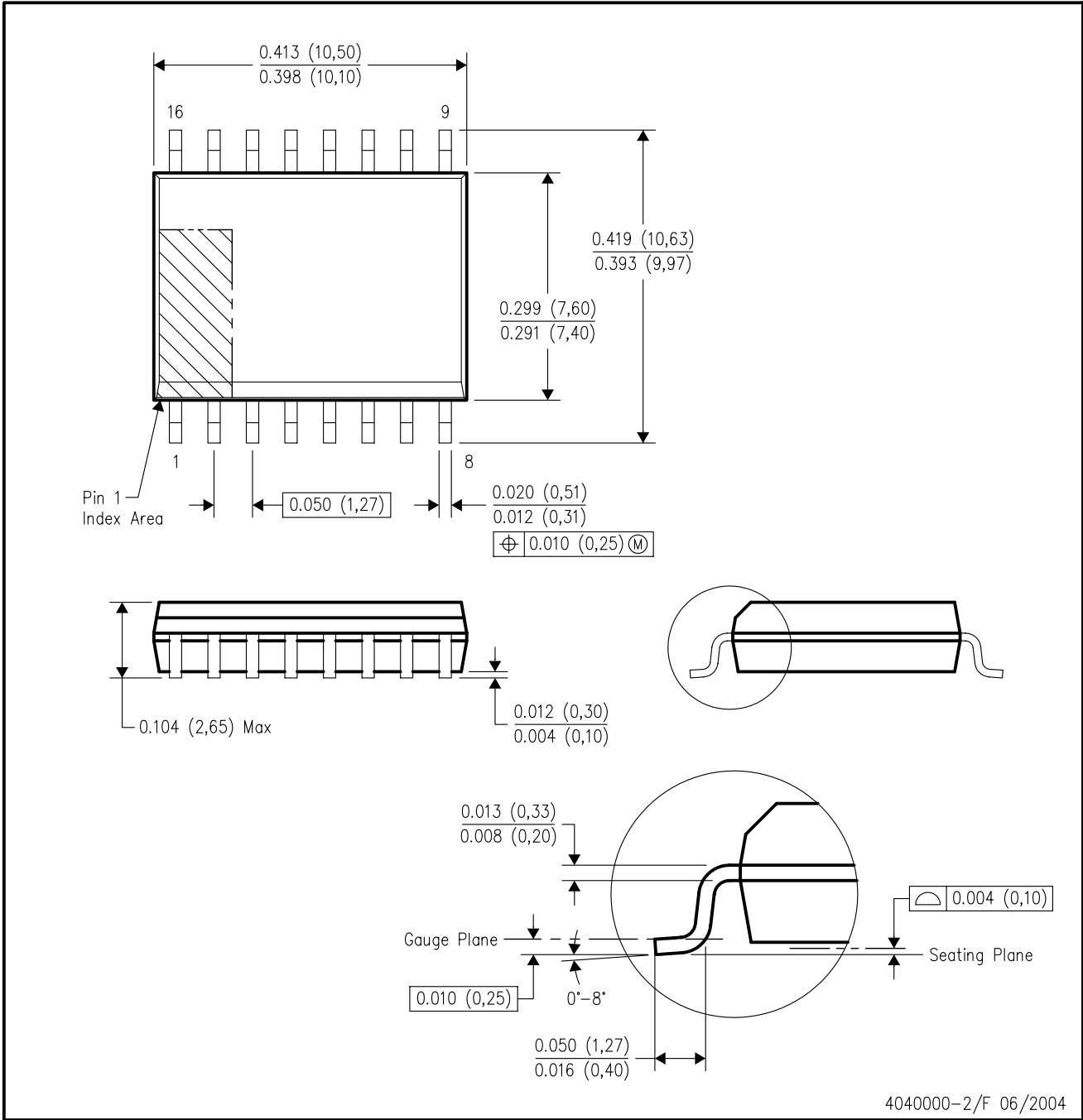

- NOTES:
- A. All linear dimensions are in inches (millimeters).
 - B. This drawing is subject to change without notice.
 - C. Body dimensions do not include mold flash or protrusion not to exceed 0.006 (0,15).
 - D. Falls within JEDEC MS-013 variation AA.

IMPORTANT NOTICE

Texas Instruments Incorporated and its subsidiaries (TI) reserve the right to make corrections, modifications, enhancements, improvements, and other changes to its products and services at any time and to discontinue any product or service without notice. Customers should obtain the latest relevant information before placing orders and should verify that such information is current and complete. All products are sold subject to TI's terms and conditions of sale supplied at the time of order acknowledgment.

TI warrants performance of its hardware products to the specifications applicable at the time of sale in accordance with TI's standard warranty. Testing and other quality control techniques are used to the extent TI deems necessary to support this warranty. Except where mandated by government requirements, testing of all parameters of each product is not necessarily performed.

TI assumes no liability for applications assistance or customer product design. Customers are responsible for their products and applications using TI components. To minimize the risks associated with customer products and applications, customers should provide adequate design and operating safeguards.

TI does not warrant or represent that any license, either express or implied, is granted under any TI patent right, copyright, mask work right, or other TI intellectual property right relating to any combination, machine, or process in which TI products or services are used. Information published by TI regarding third-party products or services does not constitute a license from TI to use such products or services or a warranty or endorsement thereof. Use of such information may require a license from a third party under the patents or other intellectual property of the third party, or a license from TI under the patents or other intellectual property of TI.

Reproduction of TI information in TI data books or data sheets is permissible only if reproduction is without alteration and is accompanied by all associated warranties, conditions, limitations, and notices. Reproduction of this information with alteration is an unfair and deceptive business practice. TI is not responsible or liable for such altered documentation. Information of third parties may be subject to additional restrictions.

Resale of TI products or services with statements different from or beyond the parameters stated by TI for that product or service voids all express and any implied warranties for the associated TI product or service and is an unfair and deceptive business practice. TI is not responsible or liable for any such statements.

TI products are not authorized for use in safety-critical applications (such as life support) where a failure of the TI product would reasonably be expected to cause severe personal injury or death, unless officers of the parties have executed an agreement specifically governing such use. Buyers represent that they have all necessary expertise in the safety and regulatory ramifications of their applications, and acknowledge and agree that they are solely responsible for all legal, regulatory and safety-related requirements concerning their products and any use of TI products in such safety-critical applications, notwithstanding any applications-related information or support that may be provided by TI. Further, Buyers must fully indemnify TI and its representatives against any damages arising out of the use of TI products in such safety-critical applications.

TI products are neither designed nor intended for use in military/aerospace applications or environments unless the TI products are specifically designated by TI as military-grade or "enhanced plastic." Only products designated by TI as military-grade meet military specifications. Buyers acknowledge and agree that any such use of TI products which TI has not designated as military-grade is solely at the Buyer's risk, and that they are solely responsible for compliance with all legal and regulatory requirements in connection with such use.

TI products are neither designed nor intended for use in automotive applications or environments unless the specific TI products are designated by TI as compliant with ISO/TS 16949 requirements. Buyers acknowledge and agree that, if they use any non-designated products in automotive applications, TI will not be responsible for any failure to meet such requirements.

Following are URLs where you can obtain information on other Texas Instruments products and application solutions:

Products

Amplifiers	amplifier.ti.com
Data Converters	dataconverter.ti.com
DSP	dsp.ti.com
Clocks and Timers	www.ti.com/clocks
Interface	interface.ti.com
Logic	logic.ti.com
Power Mgmt	power.ti.com
Microcontrollers	microcontroller.ti.com
RFID	www.ti-rfid.com
RF/IF and ZigBee® Solutions	www.ti.com/lprf

Applications

Audio	www.ti.com/audio
Automotive	www.ti.com/automotive
Broadband	www.ti.com/broadband
Digital Control	www.ti.com/digitalcontrol
Medical	www.ti.com/medical
Military	www.ti.com/military
Optical Networking	www.ti.com/opticalnetwork
Security	www.ti.com/security
Telephony	www.ti.com/telephony
Video & Imaging	www.ti.com/video
Wireless	www.ti.com/wireless

Mailing Address: Texas Instruments, Post Office Box 655303, Dallas, Texas 75265
Copyright © 2008, Texas Instruments Incorporated